

BK4 整机电器接线图（台达）

文件编号：ZB.01.BK4.10.001

文件版本：1.00

设计：_____ 日期：_____

审核：_____ 日期：_____

批准：_____ 日期：_____

BK4 整机电器接线图版本控制表

序号	历史版本号	修改记录及说明	修改人	日期
1				
2				
3				
4				
5				
6				
7				
8				
9				
10				
11				
12				
13				

BK4 整机成品线目录

序号	物料名称	规格型号	所属部件	图纸版本号	备注
1	BK4 机头 1 台达伺服控制线 head 1 Delta servo control line	BK401P	成品线	V1.0.0	线长按机型定
2	BK4 机头 2 台达伺服控制线 Head 2 Delta Servo Control Line	BK402P	成品线	V1.0.0	线长按机型定
3	TK4S 振动刀控制线Vibration knife control line	BK403P	成品线	V1.0.0	
4	BK4 主动轮刀控制线PRT control line	BK404P	成品线	V1.0.0	
5	BK4 笔部件控制线PEN control line	BK405P	成品线	V1.0.0	
6	BK4 刀具电源线Tool power line	BK406P	成品线	V1.0.0	线长按机型定
7	BK4 机头电源线Head power line	BK407P	成品线	V1.0.0	线长按机型定
8	BK4 机头控制线Head control line	BK408P	成品线	V1.0.0	线长按机型定
9	BK4 X 台达电机动力量线Delta motor power line	BK409P_XD	成品线	V1.0.0	线长按机型定
10	BK4 X 台达电机编码器线X Delta motor encoder line	BK409P_XB	成品线		线长按机型定
11	BK4 Y 台达电机动力量线Y Delta Motor Power Line	BK410P_YD	成品线	V1.0.0	线长按机身定
12	BK4 Y 台达电机编码器线Y Delta motor encoder line	BK410P_YB	成品线		线长按机身定
13	BK4 光电控制线Photoelectric sensor control line	BK411P	成品线	V1.0.0	线长按机身定
14	BK4 Y 原点光电控制线Y Origin photoelectric sensor control line	BK412P	成品线	V1.0.0	
15	BK4 防撞控制线Anti-collision sensor control line	BK413P	成品线	V1.0.0	线长按横梁定
16	BK4 压料电磁阀控制线Pressure material solenoid valve control line	BK414P	送料部件	V1.0.0	
17	BK4 摄像头控制线Camera control line	BK415P	CCD 部件	V1.0.0	线长按机型定
18	BK4 X 原点光电控制线X Origin photoelectric sensor control line	BK416P	成品线	V1.0.0	
19	BK4 换向电磁阀控制线 Reversing solenoid valve control line	BK417P	送料部件	V1.0.0	
20	BK4 电源开关控制线Power switch control line	BK418P	成品线	V1.0.0	
21	BK4 气泵电源线Air pump power line	BK419P	成品线	V1.0.0	

22	BK4 暂停控制线Pause control line	BK420P_PAUSE	成品线	V1.0.0	
23	BK4 暂停开关线Pause switch line	BK420P_2	成品线	V1.0.0	
24	BK3 X 向暂停开关控制线X direction pause switch control line	BK420P_3	成品线	V1.0.0	线长按机身定
25	BK4 Y 向暂停开关控制线Y direction pause switch control line	BK420P_4	成品线	V1.0.0	线长按横梁定
26	BK4 操作台控制线Console control line	BK421P	操作台	V1.0.0	
27	BK4 急停开关线Emergency stop switch line	BK422P_STOP1	成品线	V1.0.0	
28	BK4 操作台停开关线Operation desk stop switch line	BK422P_STOP2	操作台		
29	BK4 对刀器 1 控制线AKI1 control line	BK423P	对刀器	V1.0.0	
30	BK4 对刀器 2 控制线AKI2 control line	BK424P	对刀器		线长按横梁定
31	BK4 操作台电源线Console power line	BK4_POWER1	操作台	V1.0.0	
32					
33					
34					
35					
36					
37					
38					
39					
40					
41					
42					
43					

JP1

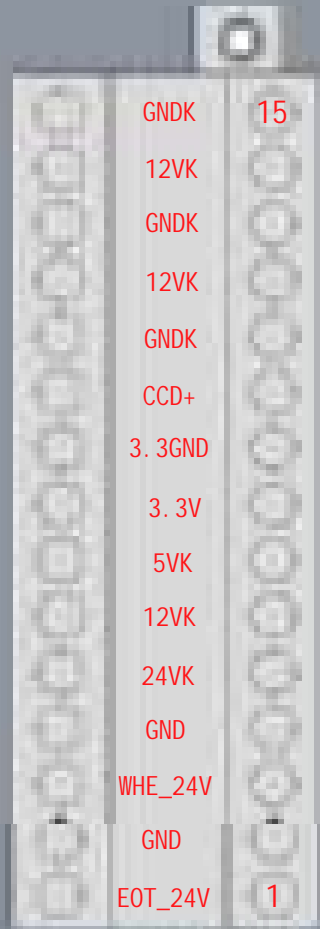

JP2

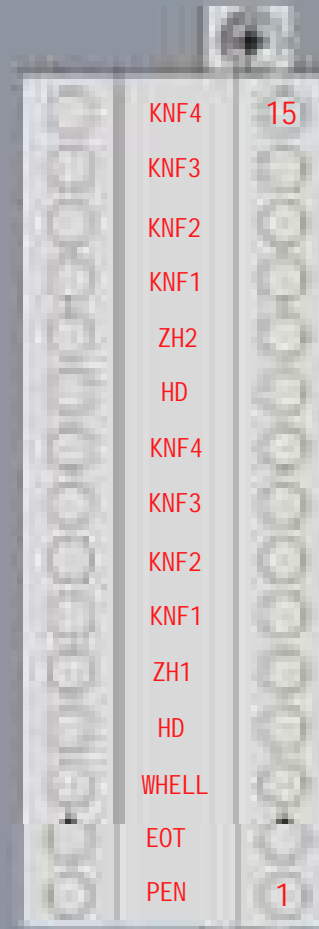

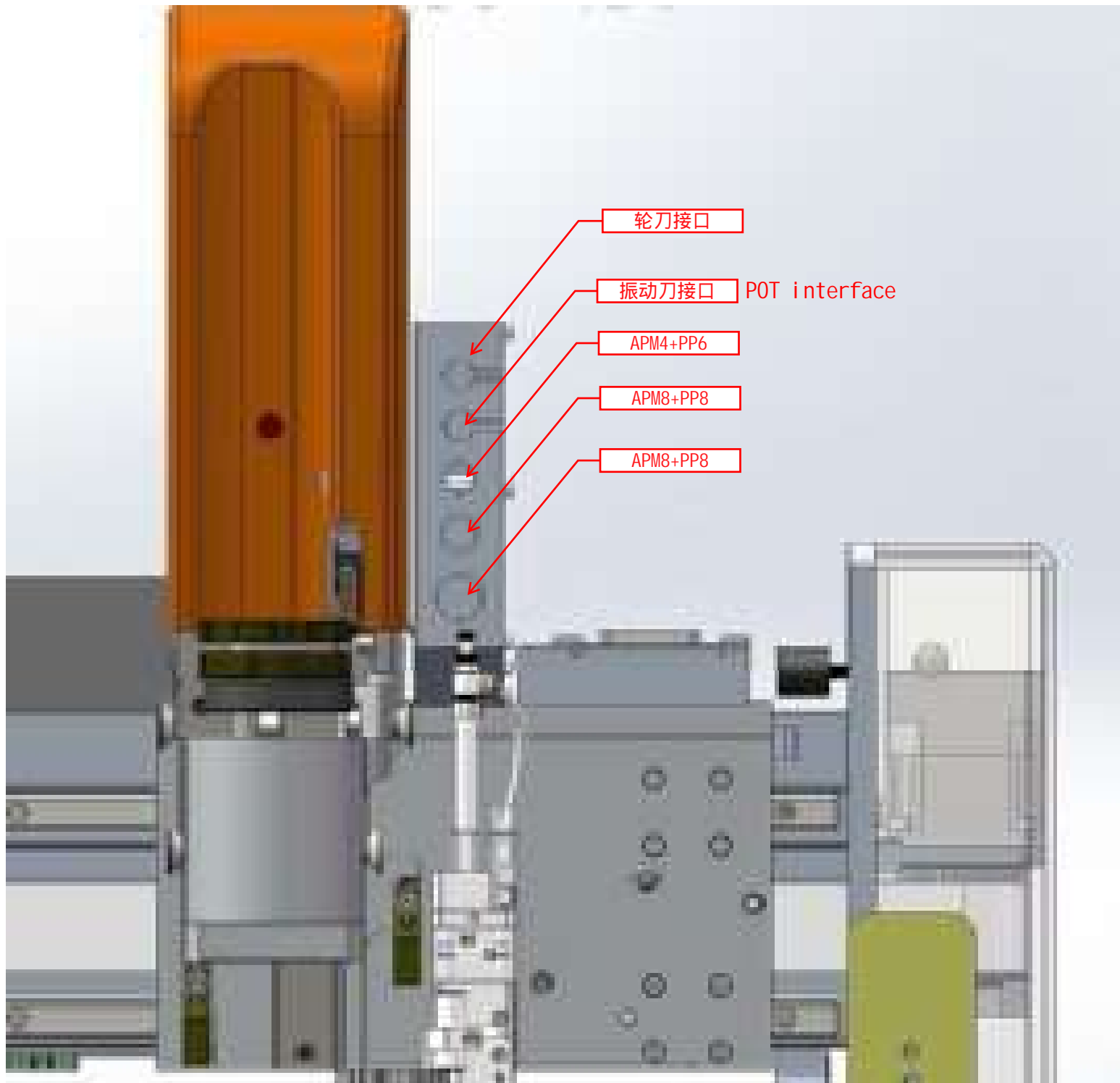

轮刀接口

振动刀接口 POT interface

APM4+PP6

APM8+PP8

APM8+PP8

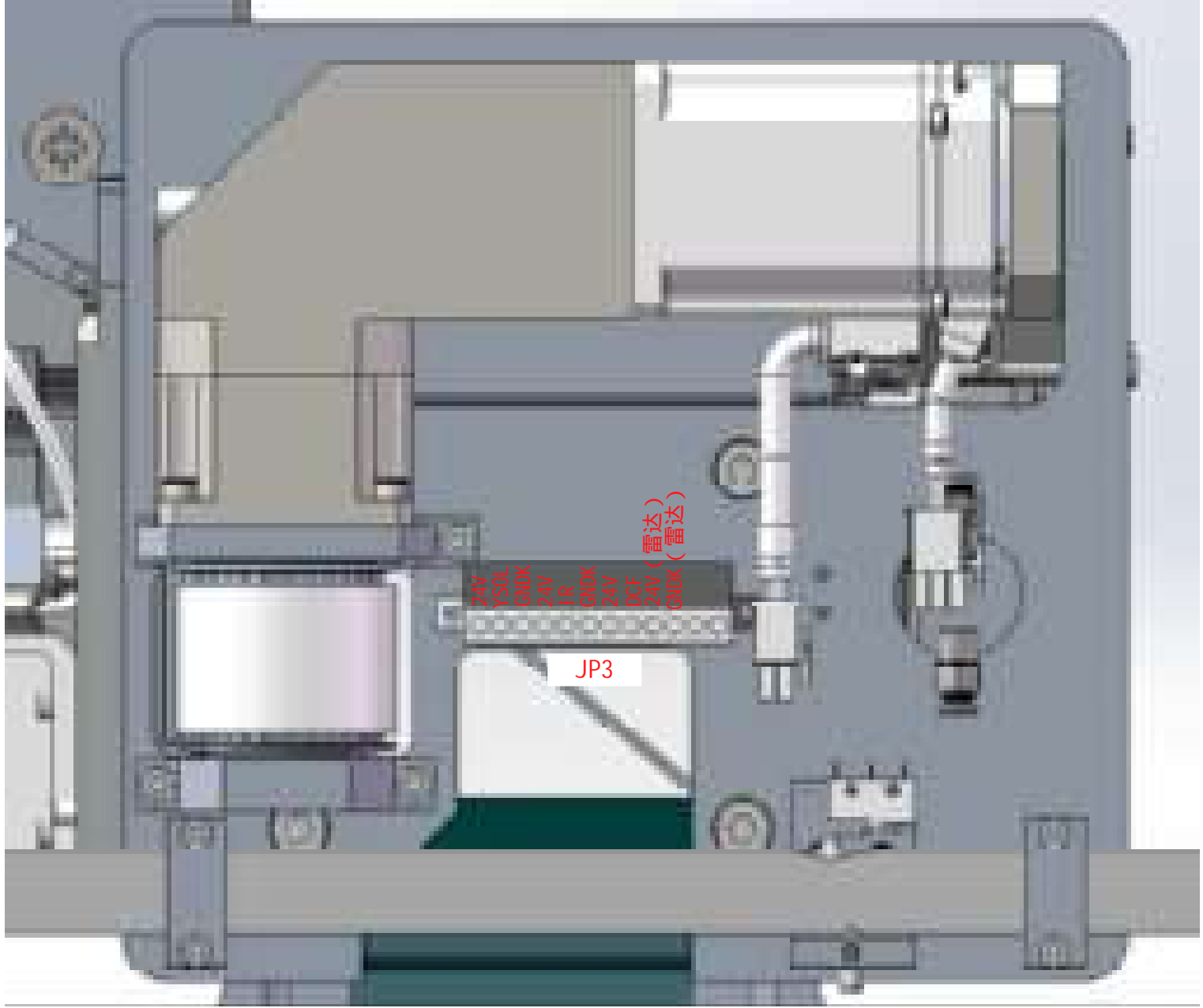

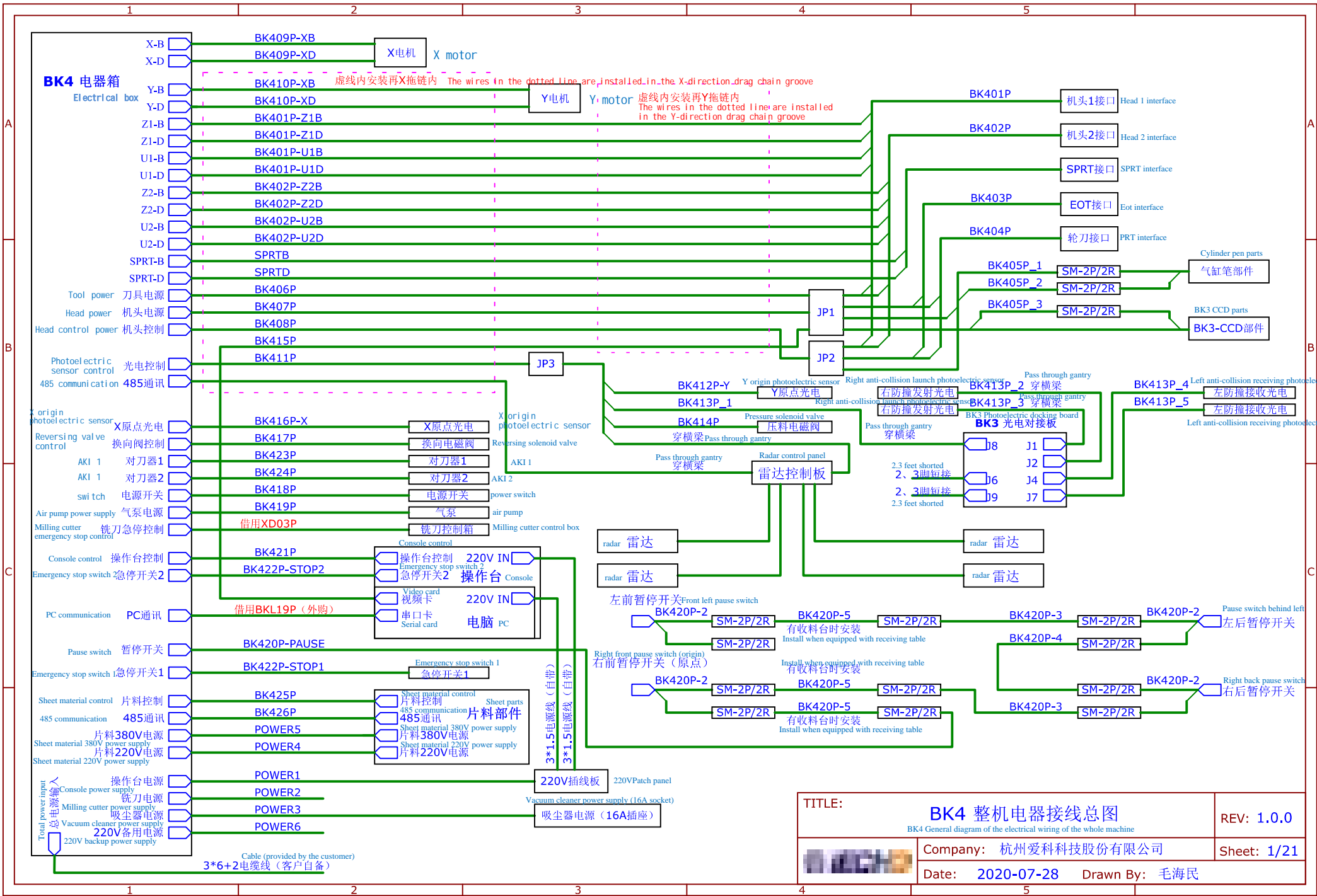

BK4 电器箱
Electrical box

- X-B BK409P-XB
- X-D BK409P-XD
- Y-B BK410P-XB
- Y-D BK410P-XD
- Z1-B BK401P-Z1B
- Z1-D BK401P-Z1D
- U1-B BK401P-U1B
- U1-D BK401P-U1D
- Z2-B BK402P-Z2B
- Z2-D BK402P-Z2D
- U2-B BK402P-U2B
- U2-D BK402P-U2D
- SPRT-B SPRTB
- SPRT-D SPRTD
- Tool power 刀具电源
- Head power 机头电源
- Head control power 机头控制
- Photoelectric sensor control 光电控制
- 485 communication 485通讯
- X origin photoelectric sensor X原点光电
- Reversing valve control 换向阀控制
- AKI 1 对刀器1
- AKI 1 对刀器2
- swi tch 电源开关
- Air pump power supply 气泵电源
- Milling cutter emergency stop control 铣刀急停控制
- Console control 操作台控制
- Emergency stop switch 2 急停开关2
- PC communication PC通讯
- Pause switch 暂停开关
- Emergency stop switch 1 急停开关1
- Sheet material control 片料控制
- 485 communication 485通讯
- 片料380V电源
- Sheet material 380V power supply
- 片料220V电源
- Sheet material 220V power supply
- Total power input 电源输入
- Console power supply 操作台电源
- 铣刀电源
- Milling cutter power supply 铣刀器电源
- Vacuum cleaner power supply 吸尘器电源
- 220V backup power supply 220V备用电源

- X电机 X motor
- Y电机 Y motor
- 虚线内安装再X拖链内 The wires in the dotted line are installed in the X-direction drag chain groove
- 虚线内安装再Y拖链内 The wires in the dotted line are installed in the Y-direction drag chain groove
- BK416P-X X原点光电 X origin photoelectric sensor
- BK417P 换向电磁阀 Reversing solenoid valve
- BK423P 对刀器1 AKI 1
- BK424P 对刀器2 AKI 2
- BK418P 电源开关 power switch
- BK419P 气泵 air pump
- 借用XD03P 铣刀控制箱 Milling cutter control box
- BK421P 操作台控制 220V IN
- BK422P-STOP2 急停开关2 操作台 Console
- 借用BKL19P (外购) 视频卡 220V IN
- 串口卡 电脑 PC
- BK425P 片料控制 Sheet material control
- BK426P 485通讯 片料部件
- POWER5 片料380V电源 Sheet material 380V power supply
- POWER4 片料220V电源 Sheet material 220V power supply
- POWER1 操作台电源 Console power supply
- POWER2 铣刀电源 Milling cutter power supply
- POWER3 吸尘器电源 Vacuum cleaner power supply
- POWER6 220V备用电源 220V backup power supply
- 3*1.5电源线 (自带) 3*1.5电源线 (自带)
- 220V插线板 220V Patch panel
- 吸尘器电源 (16A插座) Vacuum cleaner power supply (16A socket)

- BK401P 机头1接口 Head 1 interface
- BK402P 机头2接口 Head 2 interface
- SPRT接口 SPRT interface
- BK403P EOT接口 Eot interface
- BK404P 轮刀接口 PRT interface
- BK405P_1 SM-2P/2R 气缸笔部件 Cylinder pen parts
- BK405P_2 SM-2P/2R 气缸笔部件
- BK405P_3 SM-2P/2R BK3 CCD部件 BK3-CCD部件
- JP1
- JP2
- JP3
- BK412P-Y Y origin photoelectric sensor Right anti-collision launch photoelectric sensor
- BK413P_1 Y原点光电 Right anti-collision launch photoelectric sensor
- BK413P_2 右防撞发射光电 穿横梁 Pass through gantry
- BK413P_3 右防撞发射光电 穿横梁 Pass through gantry
- BK413P_4 左防撞接收光电 Left anti-collision receiving photoelectric sensor
- BK413P_5 左防撞接收光电 Left anti-collision receiving photoelectric sensor
- BK414P 压料电磁阀 Pressure solenoid valve 穿横梁 Pass through gantry
- BK3 光电对接板 BK3 Photoelectric docking board
- J1
- J2
- J4
- J7
- 2.3 feet shorted 2、3脚短接
- 2.3 feet shorted 2、3脚短接
- 2.3 feet shorted 2、3脚短接
- 雷达 radar 雷达
- 雷达 radar 雷达
- 雷达 radar 雷达
- 雷达 radar 雷达
- 左前暂停开关 Front left pause switch
- BK420P-2 SM-2P/2R 有收料台时安装 Install when equipped with receiving table
- BK420P-5 SM-2P/2R 有收料台时安装 Install when equipped with receiving table
- BK420P-3 SM-2P/2R 有收料台时安装 Install when equipped with receiving table
- BK420P-2 SM-2P/2R 左右暂停开关 Pause switch behind left
- BK420P-4 SM-2P/2R 左右暂停开关
- 右前暂停开关 (原点) Right front pause switch (origin) 有收料台时安装 Install when equipped with receiving table
- BK420P-2 SM-2P/2R 有收料台时安装 Install when equipped with receiving table
- BK420P-5 SM-2P/2R 有收料台时安装 Install when equipped with receiving table
- BK420P-3 SM-2P/2R 有收料台时安装 Install when equipped with receiving table
- BK420P-2 SM-2P/2R 右后暂停开关 Right back pause switch

Cable (provided by the customer)
3*6+2电电缆线 (客户自备)

TITLE: BK4 整机电器接线总图 BK4 General diagram of the electrical wiring of the whole machine		REV: 1.0.0
Company: 杭州爱科科技股份有限公司		Sheet: 1/21
Date: 2020-07-28	Drawn By: 毛海民	

Belongs to the finished product line
属于整机成品线

BK4 head 1 Delta private server control line BK401P
BK4 机头1台达伺服控制线BK401P

U1 drive
U1驱动器

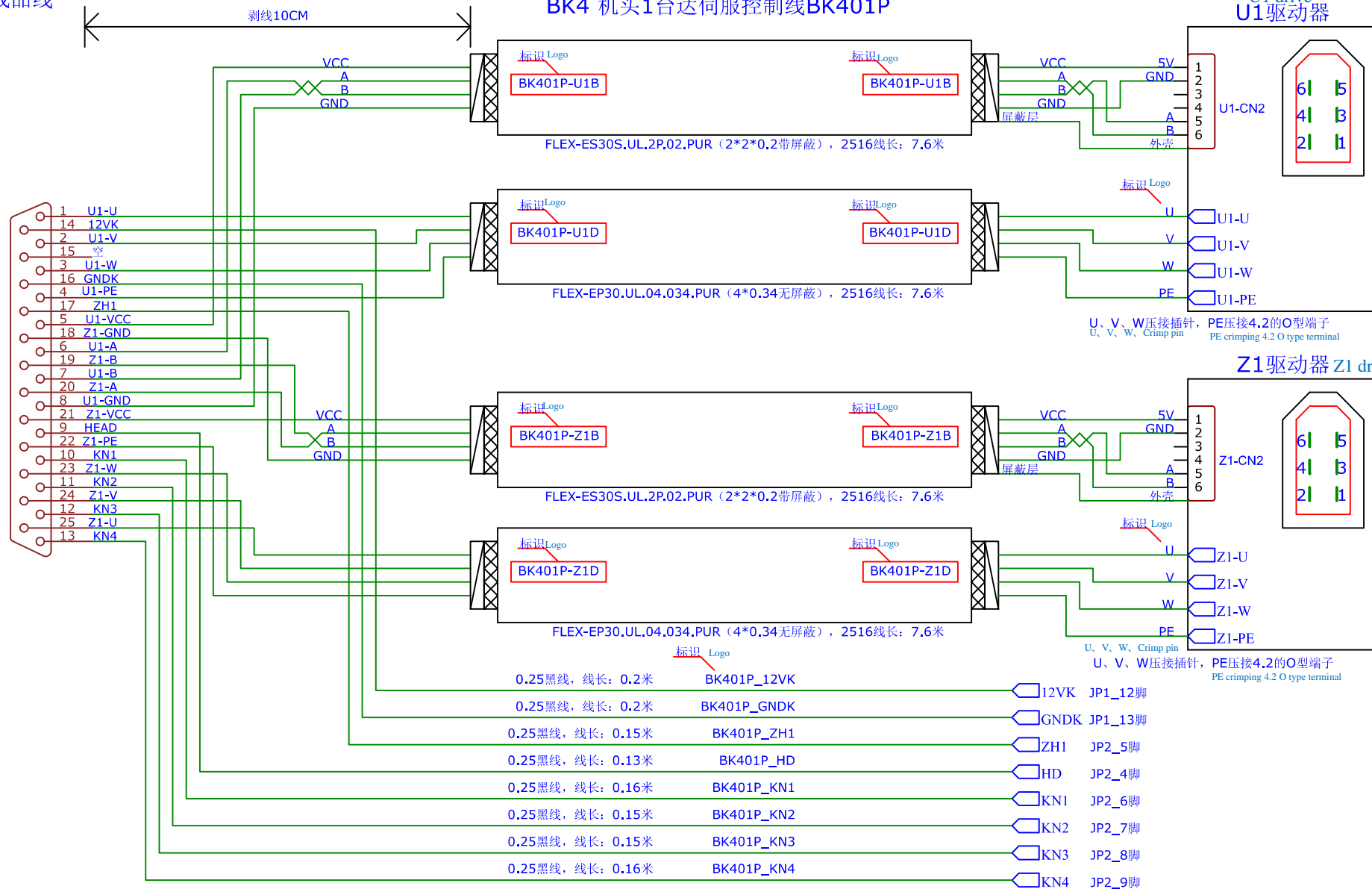

注: 标识应尽量靠近接线端

TITLE: Wiring diagram of BK4 head 1 servo control line
BK4 机头1伺服控制线接线图

REV: 1.0.0

Company: 杭州爱科科技股份有限公司

Sheet: 3/21

Date: 2020-07-28 Drawn By: 毛海民

属于整机成品线

BK4 head 2 Delta private server control line BK402P
BK4 机头2台达伺服控制线BK402P

U2驱动器 U1 drive

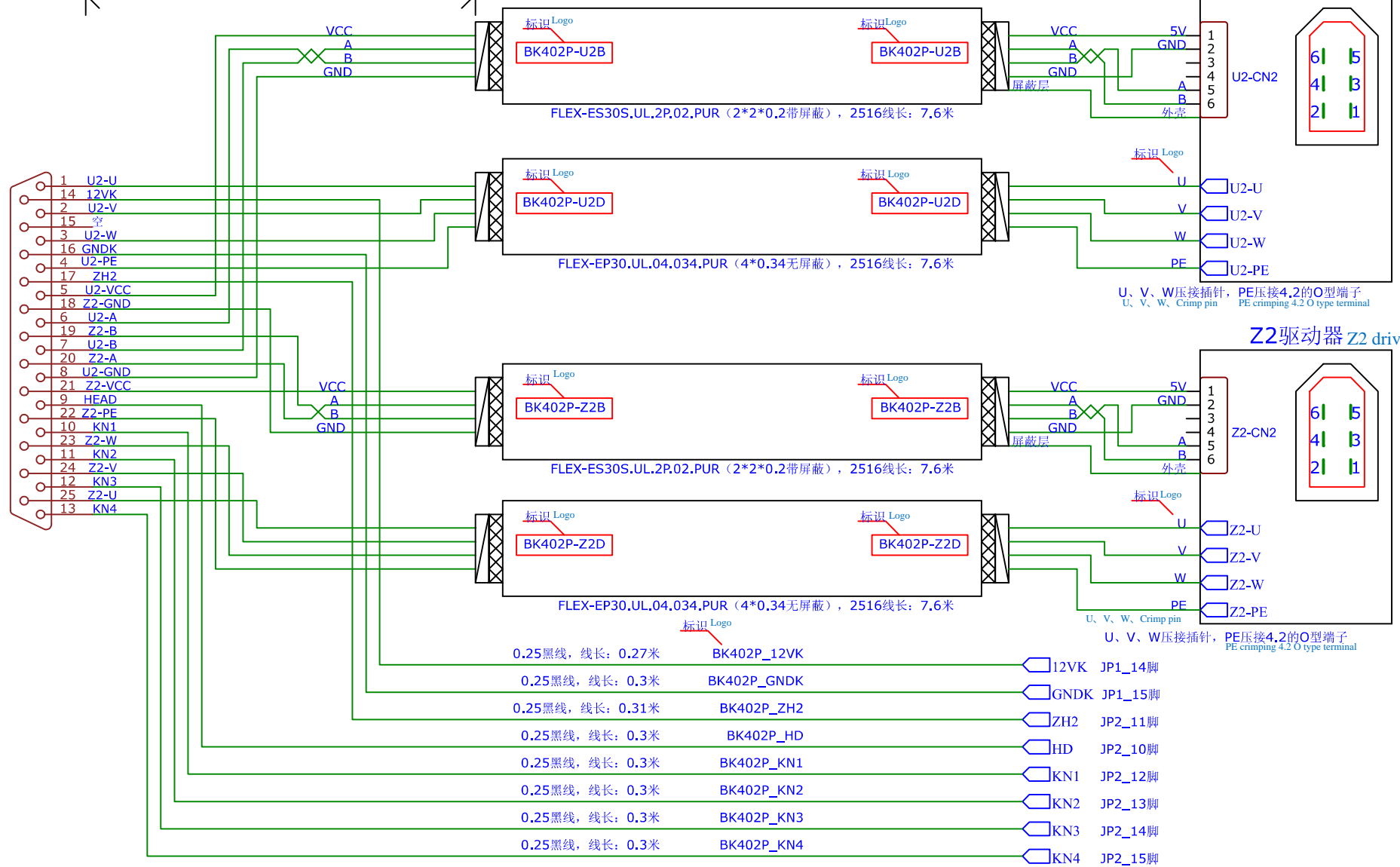

注: 标识应尽量靠近接线端

TITLE:	Wiring diagram of BK4 head 2 servo control line BK4 机头2台达伺服控制线接线图	REV: 1.0.0
Company:	杭州爱科科技股份有限公司	Sheet: 4/21
Date:	2020-07-28	Drawn By: 毛海民

属于整机成品线

TK4S EOT control line BK403P TK4S振动刀控制线BK403P

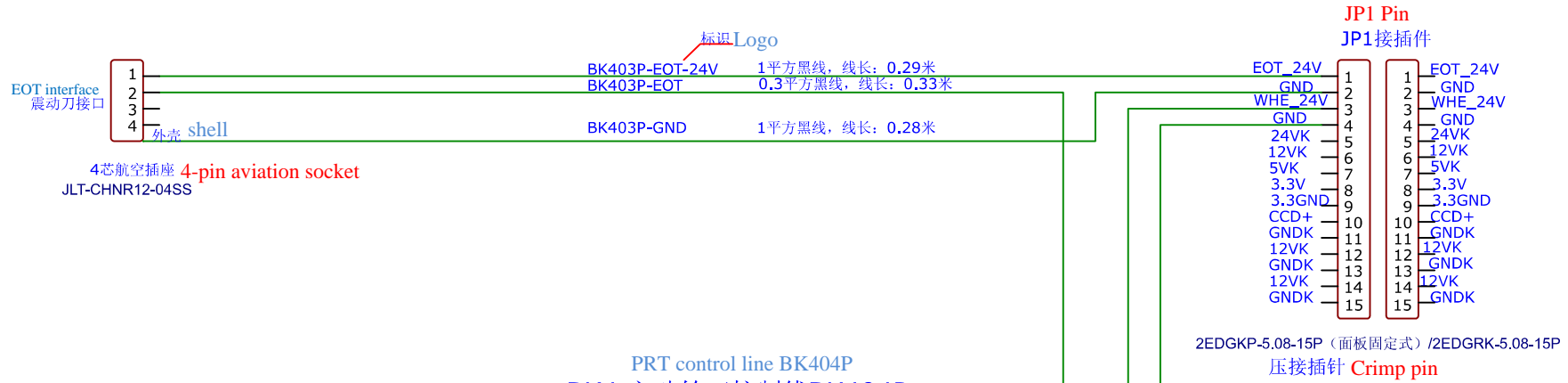

PRT control line BK404P BK4 主动轮刀控制线BK404P



TITLE:	BK4 Tool Control Wiring Diagram BK4 刀具控制线接线图	REV: 1.0.0
	Company: 杭州爱科科技股份有限公司	Sheet: 5/21
	Date: 2020-07-28	Drawn By: 毛海民

属于选配线

BK4 pen component & CCD component control line BK405P
BK4 笔部件&CCD部件控制线BK405P

BKL pen component
BKL气缸笔部件

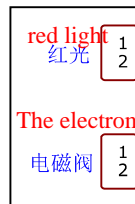

标识logo
BK405P_5VK 0.3黑线, 线长: 0.15米
BK405P_GNDK 0.3黑线, 线长: 0.15米

标识logo
BK405P_24VK 0.3黑线, 线长: 0.15米
BK405P_PEN 0.3黑线, 线长: 0.15米

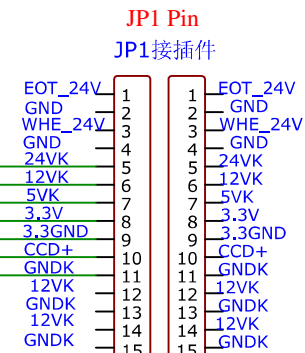

2EDGKP-5.08-15P (面板固定式) /2EDGRK-5.08-15P

压接插针Crimp pin

BK3-CCD部件



标识logo
BK304P_1
BK304P_2

高温线(红)
高温线(黑)
高温线(蓝)

3.3V
3.3GND
CCD+

标识logo
BK306P_3
BK306P_4

SM-2P SM-2R
BK405P_12VK 0.3黑线, 线长: 0.15米
BK405P_GNDK 0.3黑线, 线长: 0.15米

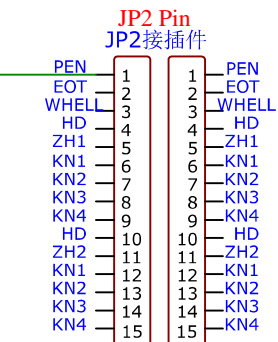

2EDGKP-5.08-15P (面板固定式) /2EDGRK-5.08-15P

压接插针Crimp pin

TITLE: BK4 pen component & CCD component control line BK4 气缸笔部件和CCD部件接线图		REV: 1.0.0
Company: 杭州爱科科技股份有限公司		Sheet: 6/21
Date: 2020-07-28		Drawn By: 毛海民

属于整机成品线

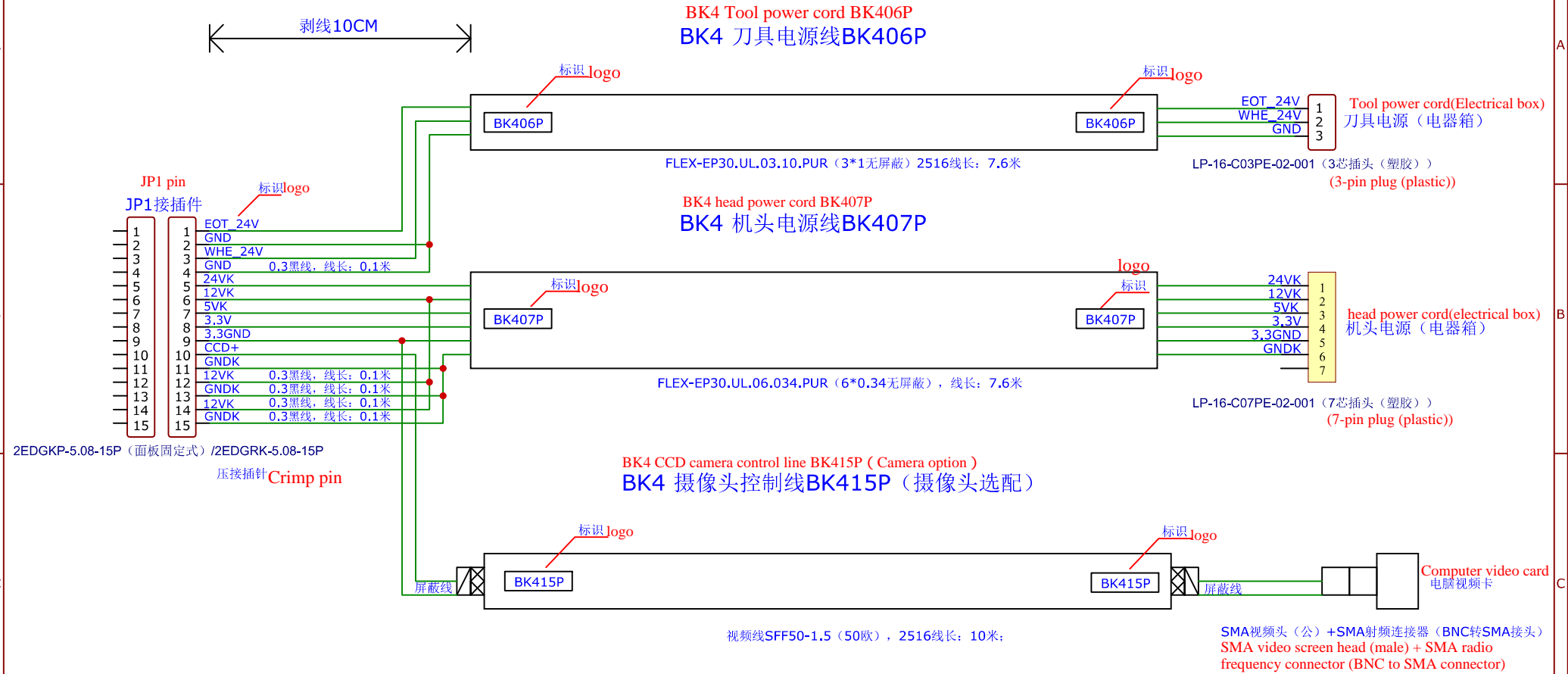

TITLE:	BK4 head carriage JP1 connector wiring diagram BK4 机头托板JP1接插件接线图	REV: 1.0.0
Company:	杭州爱科科技股份有限公司	Sheet: 7/21
Date:	2020-07-28	Drawn By: 毛海民

属于整机成品线

BK4 head control line BK408P
BK4 机头控制线BK408P

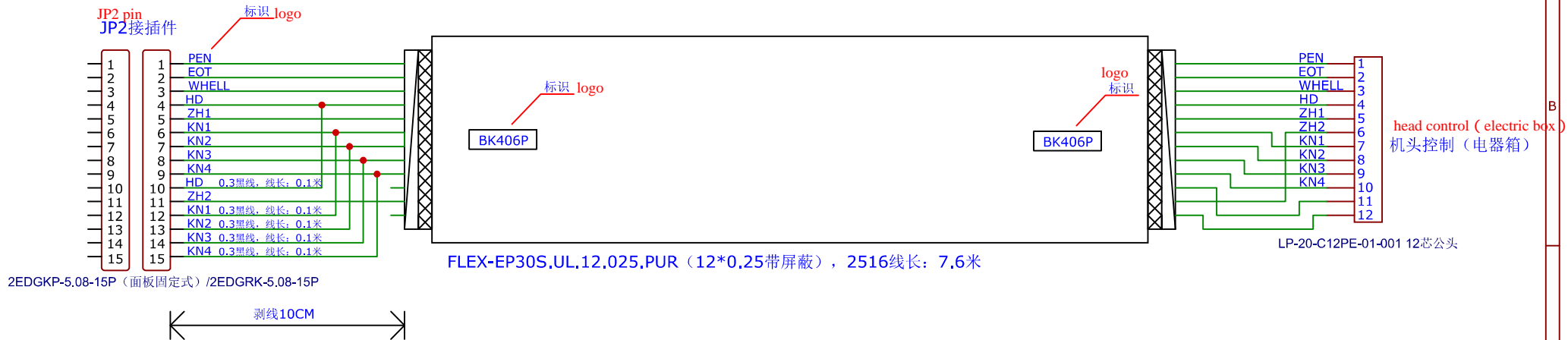

TITLE:	BK4 head control line diagram BK4 机头控制线接线图	REV: 1.0.0
	Company: 杭州爱科科技股份有限公司	Sheet: 8/21
	Date: 2020-07-28	Drawn By: 毛海民

属于整机成品线

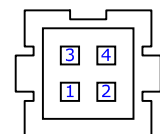
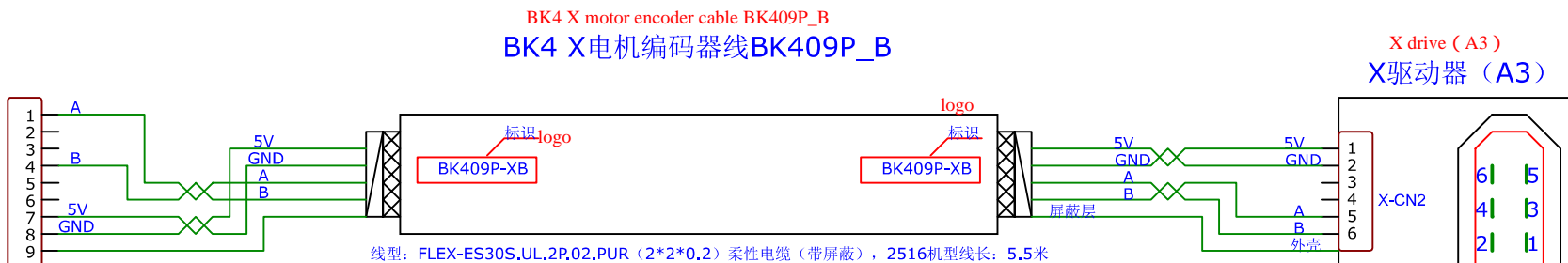
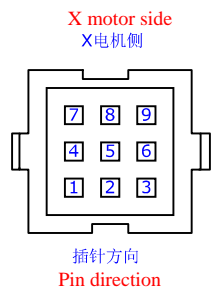

TITLE:	BK4 X motor control line diagram BK4 X电机控制线接线图	REV: 1.0.0
	Company: 杭州爱科科技股份有限公司	Sheet: 9/21
	Date: 2020-07-28	Drawn By: 毛海民

属于整机成品线

BK4 Y motor encoder cable BK410P_B
BK4 Y电机编码器线BK410P_B

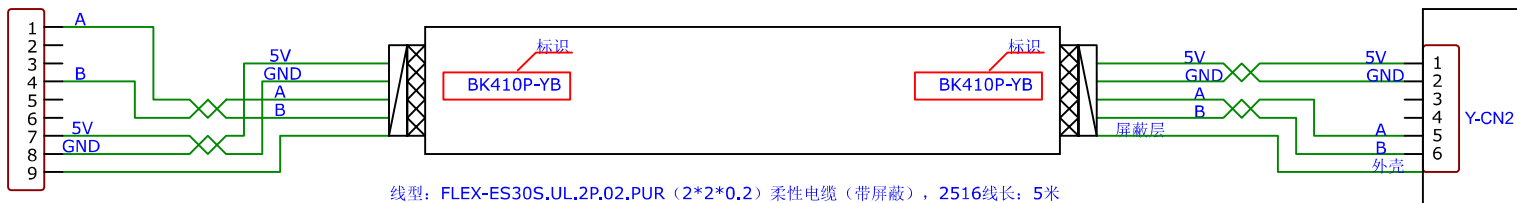
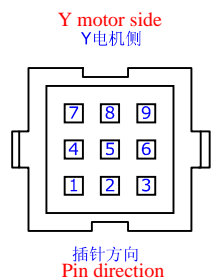

BK4 X motor power line BK410P_D
BK4 Y电机动力线BK410P_D

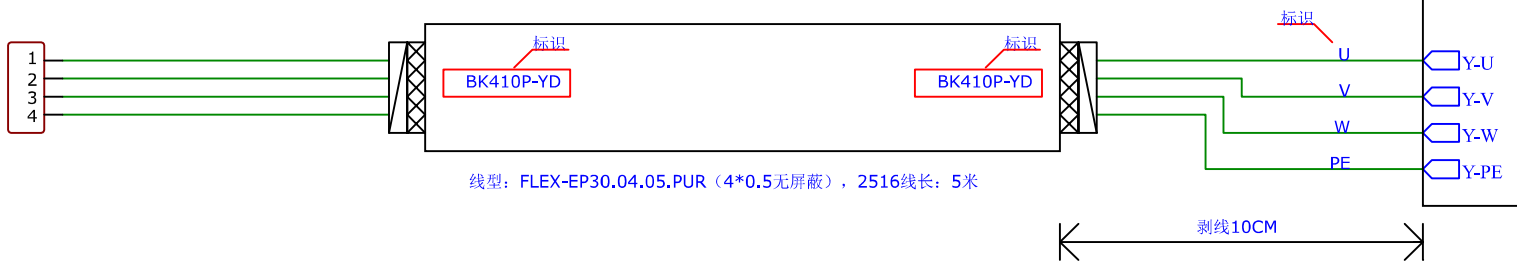
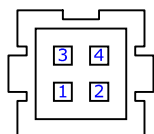

U, V, W 压接插针, PE 压接4.20型端子
U, V, W crimping pin, PE crimping 4.20 type terminal

TITLE: BK4 Y motor control line diagram BK4 Y电机控制线接线图	REV: 1.0.0
Company: 杭州爱科科技股份有限公司	Sheet: 10/21
Date: 2020-07-28	Drawn By: 毛海民

属于整机成品线

BK4 Photoelectric control line BK411P

BK4 光电控制线BK411P

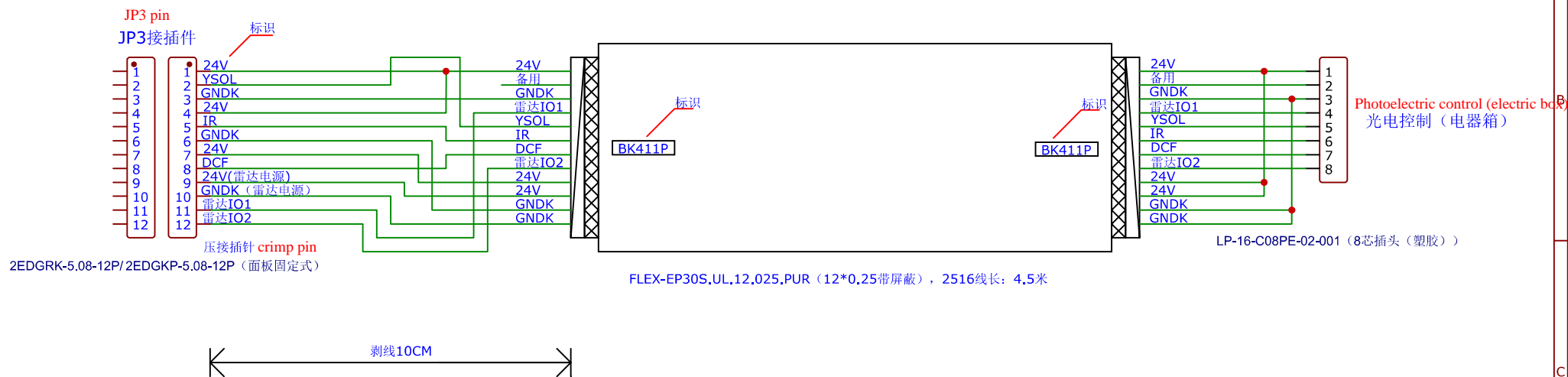

TITLE: BK4 Photoelectric control line diagram BK4 光电控制线接线图	REV: 1.0.0
Company: 杭州爱科科技股份有限公司	Sheet: 11/21
Date: 2020-07-28	Drawn By: 毛海民

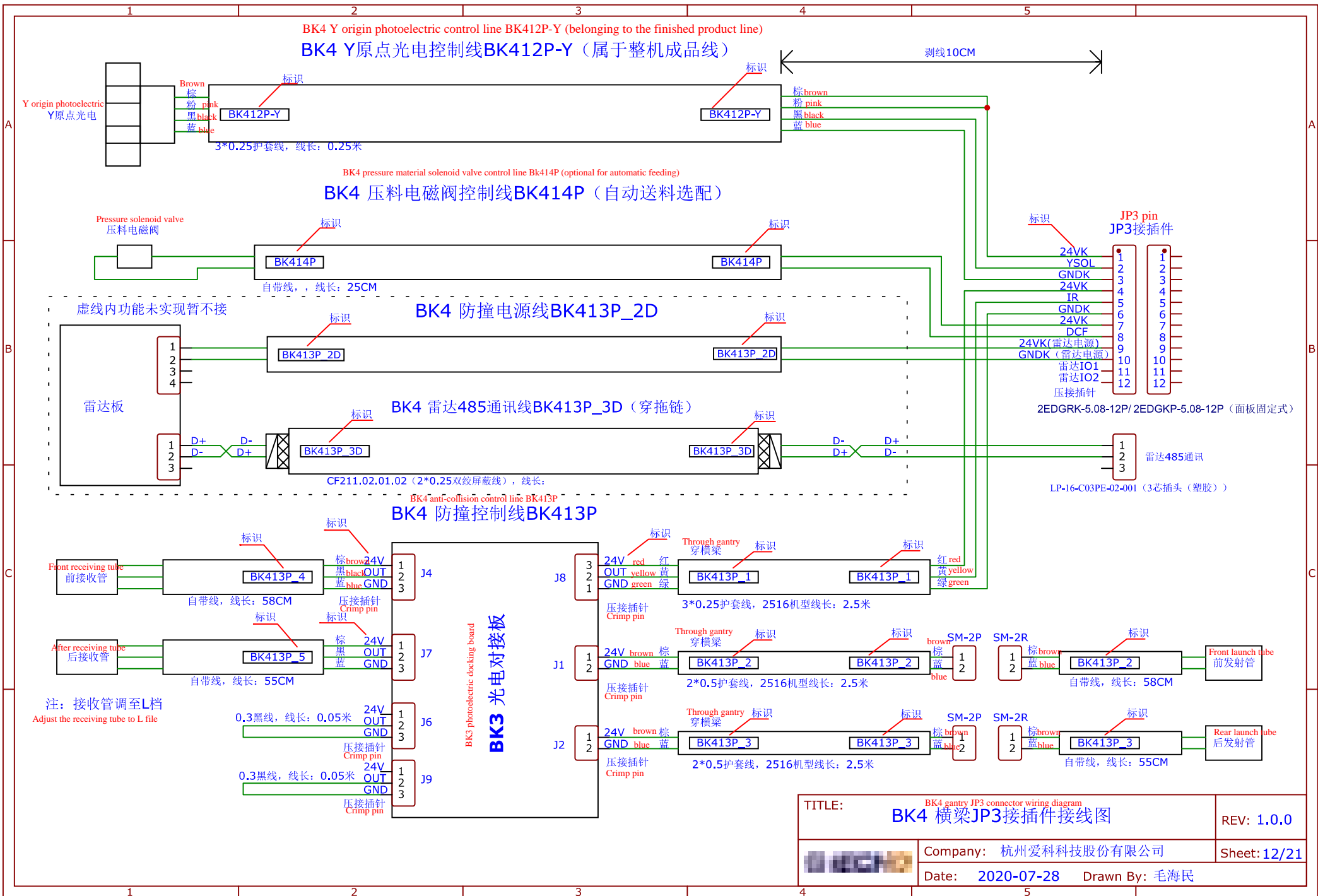

TITLE: BK4 gantry JP3 connector wiring diagram BK4 横梁JP3接插件接线图		REV: 1.0.0
Company: 杭州爱科科技股份有限公司		Sheet: 12/21
Date: 2020-07-28		Drawn By: 毛海民

属于整机成品线

BK4 X origin photoelectric control line BK416P-X
BK4 X原点光电控制线BK416P-X



TITLE: BK4 X origin control line wiring diagram BK4 X原点控制线接线图	REV: 1.0.0
Company: 杭州爱科科技股份有限公司	Sheet: 13/21
Date: 2020-07-28	Drawn By: 毛海民

属于送料部件

BK4 reversing solenoid valve control line BK417P
BK4 换向电磁阀控制线BK417P

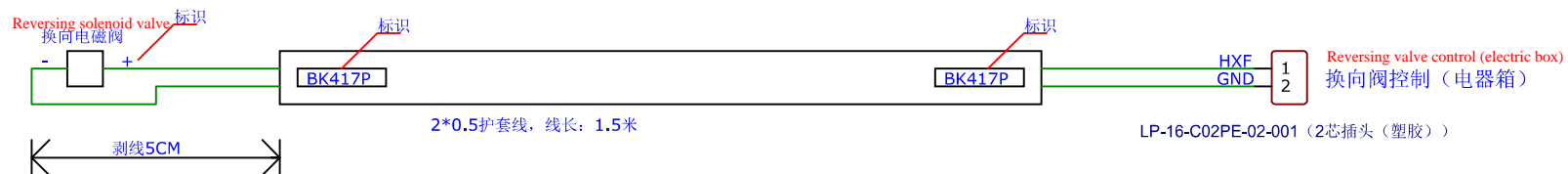

TITLE: BK4 reversing solenoid valve control wiring diagram BK4 换向电磁阀控制线接线图	REV:1.0.0
Company: 杭州爱科科技股份有限公司	Sheet:14/21
Date: 2020-07-28	Drawn By: 毛海民

属于整机成品线

BK4 power switch control line BK418P
BK4电源开关控制线BK418P

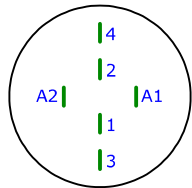
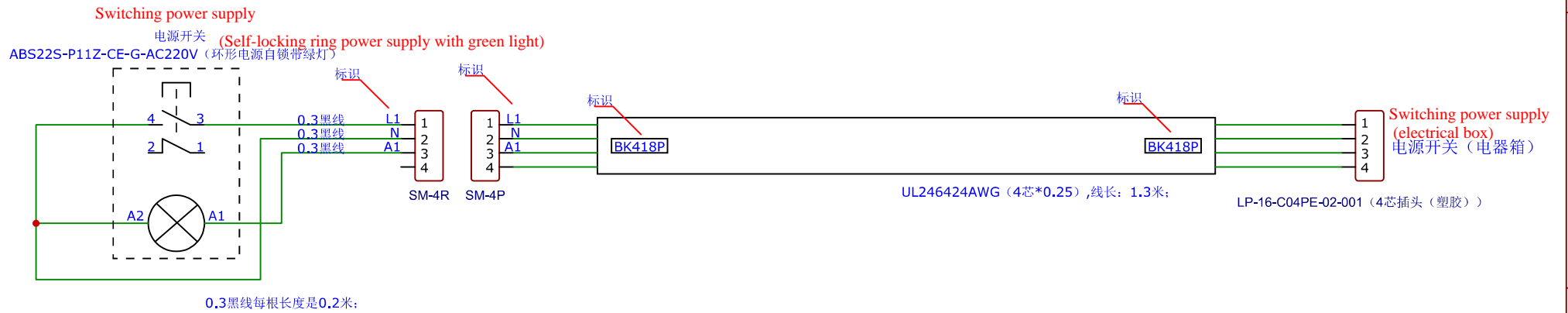

TITLE: BK4 power switch control wire wiring diagram BK4电源开关控制线接线图		REV: 1.0.0
Company: 杭州爱科科技股份有限公司		Sheet: 15/21
Date: 2020-07-28		Drawn By: 毛海民

属于BK4气泵部件

BK4 air pump power cord BK419P
BK4气泵电源线BK419P

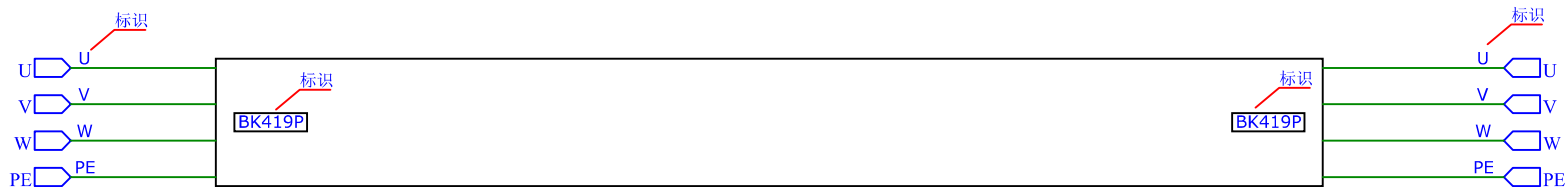

压接O型接线端子，要求紫铜材质厚度在1mm以上
For crimping O-type terminal blocks, the thickness of red copper material is required to be more than 1mm

线型：3*6+1电缆线，线长：2.5米；

注：线两端做好标识；

压接O型接线端子，要求紫铜材质厚度在1mm以上
For crimping O-type terminal blocks, the thickness of red copper material is required to be more than 1mm

TITLE: BK4 air pump power cord wiring diagram BK4气泵电源线接线图		REV: 1.0.0
	Company: 杭州爱科科技股份有限公司	Sheet: 16/21
	Date: 2020-07-28	Drawn By: 毛海民

属于整机成品线

BK4 pause control line BK420P-PAUSE BK4 暂停控制线BK420P-PAUSE

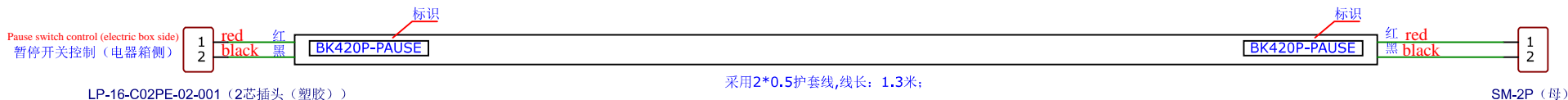

BK4 pause switch line BK420P_2 (this line has 4 lines per device) BK4 暂停开关线BK420P_2 (此款线一台设备用4根)

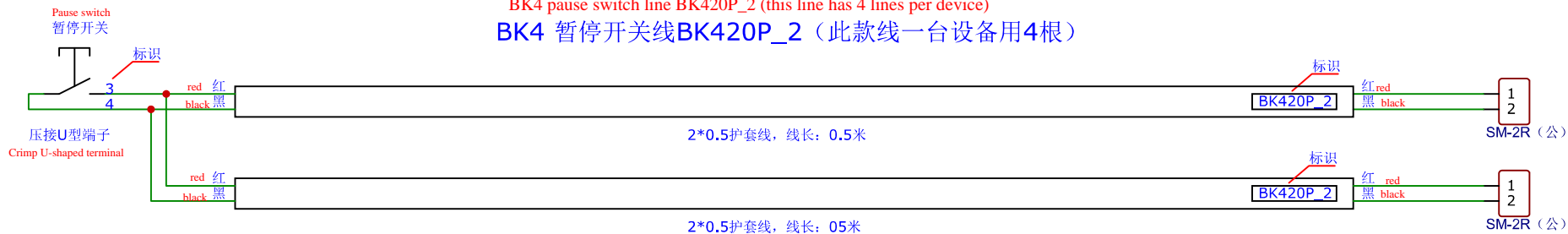

BK4 X direction BK4 pause switch control line BK420P_3 (this line has 2 lines per device) BK4 X向暂停开关控制线BK420P_3 (此款线一台设备用2根)

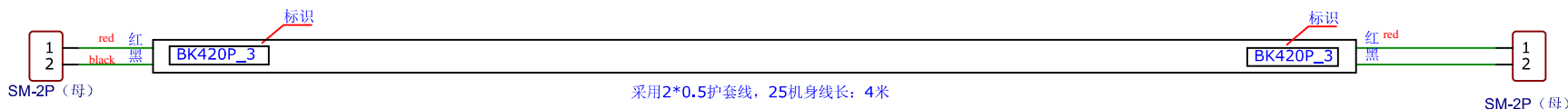

BK4 X direction BK4 pause switch control line BK420P_4 BK4 Y向暂停开关控制线BK420P_4

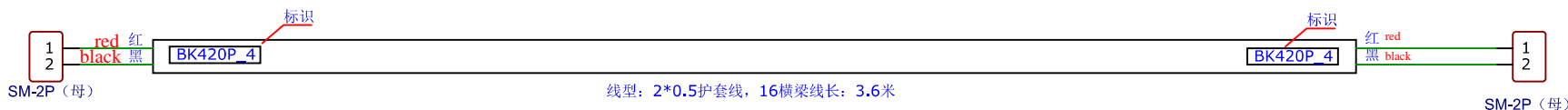

属于收料台部件

BK4 收料台暂停开关控制线BK420P_5 (有收料台时选配, 数量是3根) BK4 Receiving station pause switch control line BK420P_5 (optional when there is a receiving station, the quantity is 3)

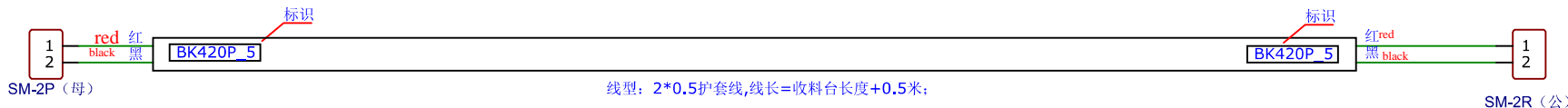

TITLE: BK4 pause switch control line wiring diagram TK4S-暂停开关控制线接线图		REV: 1.0.0
Company: 杭州爱科科技股份有限公司		Sheet: 17/21
Date: 2020-07-28		Drawn By: 毛海民

属于操作台部件

BK4 console control line BK421P
BK4操作台控制线BK421P

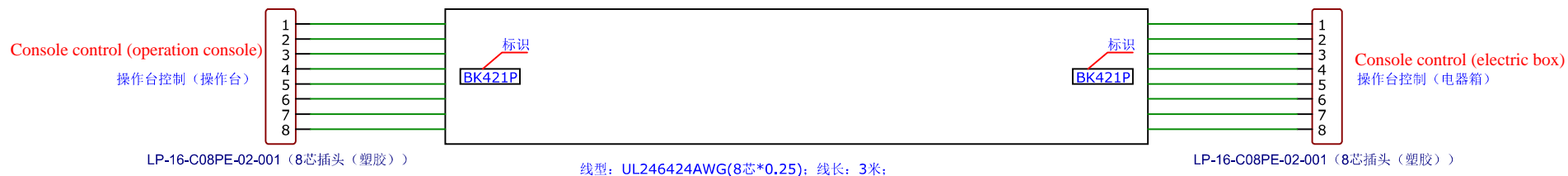

TITLE: BK4 console control line wiring diagram BK4操作台控制线接线图		REV: 1.0.0
Company: 杭州爱科科技股份有限公司		Sheet: 18/21
Date: 2020-07-28		Drawn By: 毛海民

属于整机成品线

BK4 emergency stop switch line BK422P_STOP1
BK4急停开关线BK422P_STOP1

Emergency stop switch
急停开关

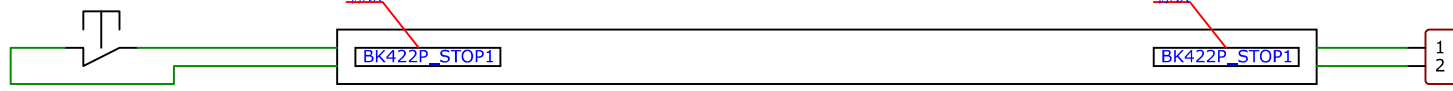

2*0.5护套线, 线长: 1.3米

LP-16-C02PE-02-001 (2芯插头(塑胶))

Emergency stop switch 1 (side of electrical box)
急停开关1 (电器箱侧)

属于操作台部件

BK4 Console emergency stop switch line BK422P_STOP2
BK4操作台急停开关线BK422P_STOP2

Emergency stop switch (operator side)
急停开关 (操作台侧)

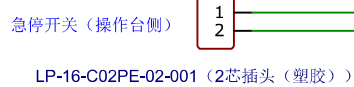

2*0.5护套线, 线长: 3米

LP-16-C02PE-02-001 (2芯插头(塑胶))

Emergency stop switch 2 (side of electrical box)
急停开关2 (电器箱侧)

TITLE:	BK4 emergency stop switch diagram BK4急停开关线接线图	REV: 1.0.0
	Company: 杭州爱科科技股份有限公司	Sheet: 19/21
Date: 2020-07-28	Drawn By: 毛海民	

对刀器选配

BK4-tool setter 1 control line BK423P BK4-对刀器1控制线BK423P

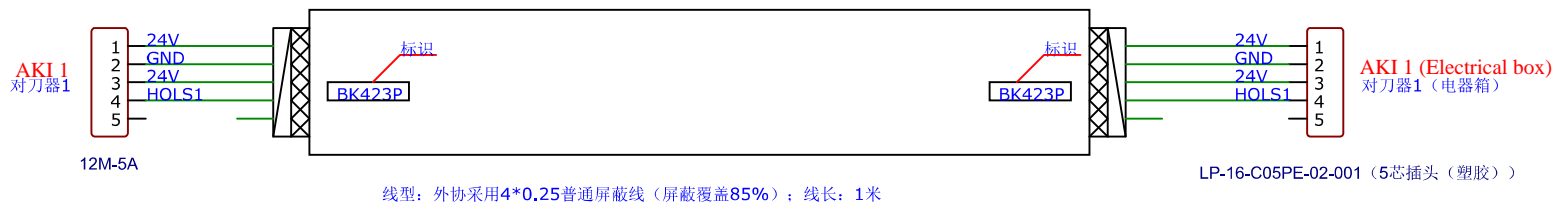

双对刀器选配

BK4-tool setter 2 control line BK424P BK4-对刀器2控制线BK424P

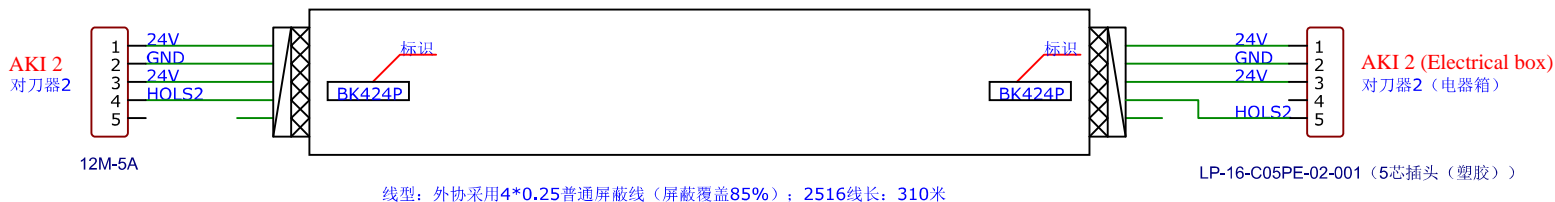

TITLE: BK4-Knife setter control line wiring diagram BK4-对刀器控制线接线图		REV: 1.0.0
Company: 杭州爱科科技股份有限公司		Sheet: 20/21
Date: 2020-07-28		Drawn By: 毛海民

属于整机成品线

BK4 console power cord BK4_POWER1
BK4操作台电源线BK4_POWER1

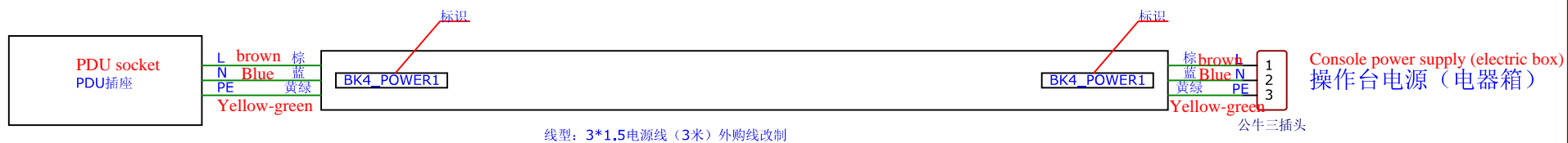

TITLE:	BK4操作台电源线接线图	REV: 1.0.0
	Company: 杭州爱科科技股份有限公司	Sheet: 21/21
Date: 2020-07-28	Drawn By: 毛海民	