



# **Product catalog**

**--- Accessories and Consumables**

**Hangzhou IECHO Science & Technology Co., Ltd.**

# Content

1. BK Accessories and Consumables.....	2
2. BK2 Accessories and Consumables.....	5
3. BK3 Accessories and Consumables.....	7
4. TK3S Accessories and Consumables.....	10
5. PK Accessories and Consumables.....	13
6. Universal Parts List.....	18
7. Consumable Parts List.....	22

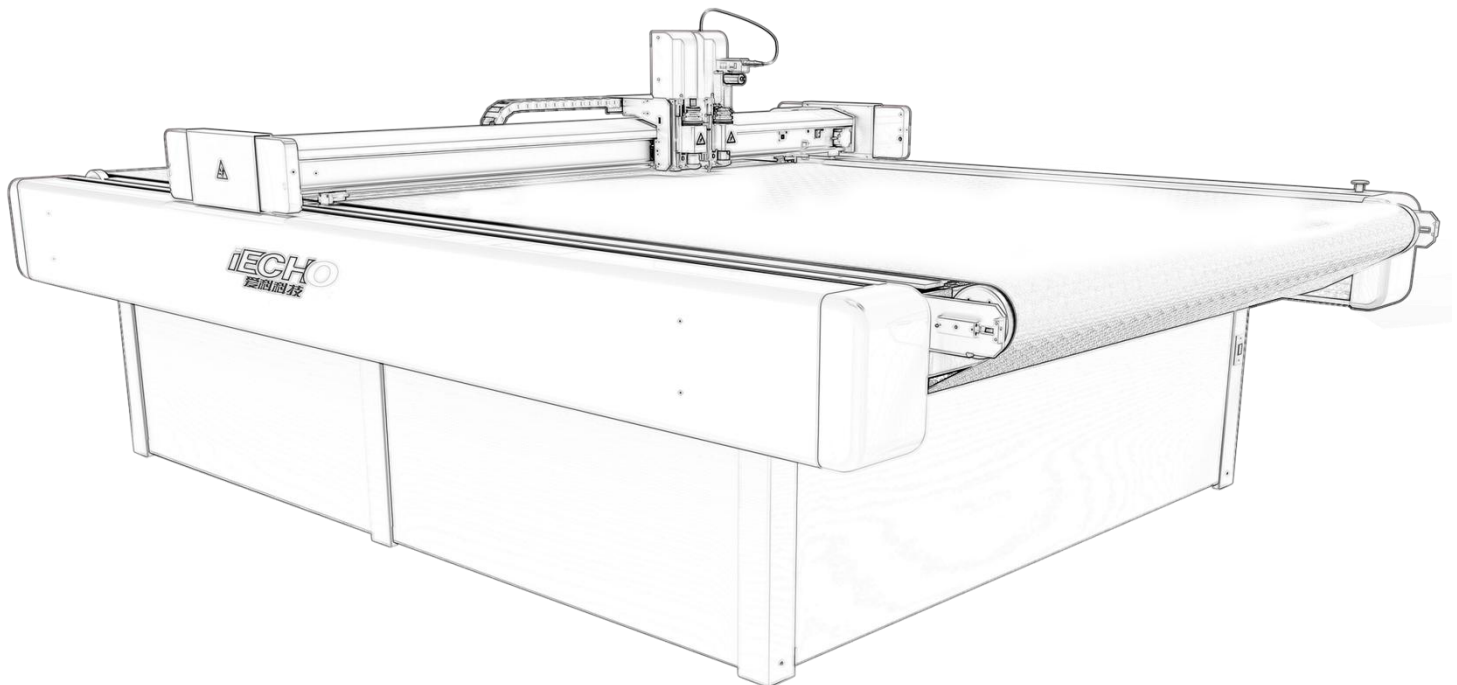

## BK Accessories and Consumables





## 1. BK - Series





Item	Designation
1	Combine the modules
2	Circuit boards and CCD module

### Combine the modules

Item	Figure	Name	Article no.	Version	Description
1		Universal cutting head	1.10.03.0000 137	BK.BK2.TK	Can hold tools like EOT . POT . UCT . KCT . 350W router spindle etc .
2		Notch & Punch head	1.10.03.0000 570	BK.BK2.TK	Can make I . V . O shape mark on material

### Circuit boards and CCD module

Item	Figure	Name	Article no.	Version	Description
1		Power & driver board	1.10.04.0000 011	BK.TK	DC power and signal relay board for DSP
2		A board	1.10.04.0000 032	BK.TK	Power and control signal for X.Y sensor .obstacle signal .
3		B board	1.10.04.0000 057	BK.TK	Power and control signal for heads .camera ,red-light .

Item	Figure	Name	Article no.	Version	Description
4		C board	1.10.04.0000 031	BK.BK2TK	POT tool .350W router Control signal
5		EPOS board	1.10.04.0000 013	BK.TK	Motion control signal transfer between DSP sever drivers
6		Power interface board	1.10.04.0000 034	BK.TK	Power interface between serve drivers and serve motors
7		Signal interface board	1.10.04.0000 035	BK.TK	Signal interface between control box and machine
8		CCD module	1.10.03.0000 154	BK.BK2.TK	Combined with red-light and camera

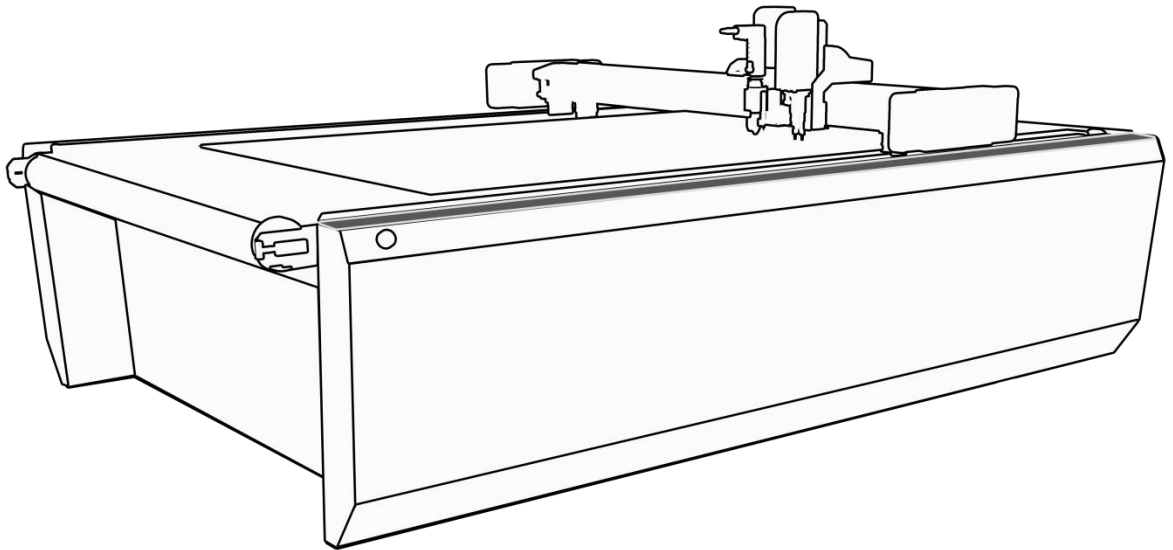

## BK2 Accessories and Consumables





## 2. BK2 - Series

Item	Designation
1	Combine the modules
2	Circuit boards

### Combine the modules

Item	Figure	Name	Article no.	Version	Description
1		Universal cutting head	1.10.03.0000 137	BK.BK2.TK	Can hold tools like EOT . POT . UCT . KCT . 350W router spindle etc .
2		Notch & Punch head	1.10.03.0000 570	BK.BK2.TK	Can make I . V . O shape mark on material

### Circuit boards

Item	Figure	Name	Article no.	Version	Description
1		Power & driver board	1.10.04.0000 116	BK2	DC power and signal relay board for DSP
2		B board	1.10.04.0000 115	BK2	Power and control signal for heads . camera , red-light .
3		EPOS board	1.10.04.0000 013	BK2	Motion control signal transfer between DSP sever drivers

## BK3 Accessories and Consumables

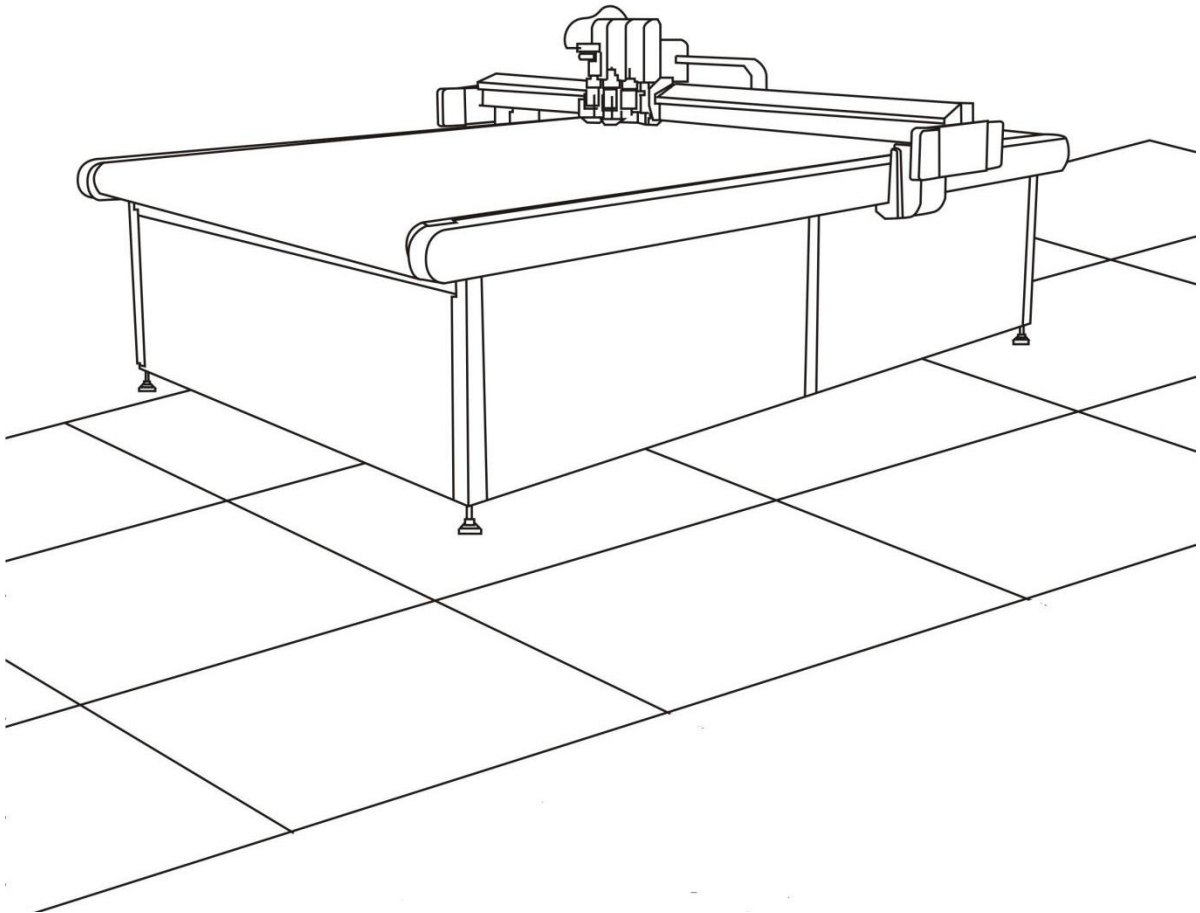







### 3. BK3 - Series

Item	Designation
1	Combine the modules
2	Circuit boards and CCD module

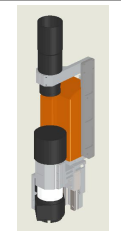
#### Combine the modules

Item	Figure	Name	Article no.	Version	Description
1		Universal cutting head	1.10.03.000 0083	BK3.TK3S. TK4S	Can hold tools like EOT . POT . UCT . KCT . 350W router spindle etc .
2		Notch & Punch head	1.10.03.000 0528	BK3.TK3S. TK4S	Can make I . V . O shape mark on material
3		1KW	1.10.03.000 2097	BK3.TK3S. TK4S	Can cut acrylic, MDF, ABS, etc
4		1.8KW	1.10.03.000 5025	BK3.TK3S. TK4S	Can cut acrylic, MDF, ABS, etc
5		Labeling head	1.10.03.000 4349	BK3.TK3S. TK4S	Attaching label for pattern after printing

**Circuit boards and CCD module**

Item	Figure	Name	Article no.	Version	Description
1		Power& driver board	1.10.04.0000 074	BK3	DC power and signal relay board for DSP
2		A board	1.10.04.0000 087	BK3	Power and control signal for X.Y sensor .obstacle signal .
3		B board	1.10.04.0000 088	BK3	Power and control signal for heads .camera ,red-light .
4		C board	1.10.04.0000 076	BK3.TK3S. TK4S	POT tool .350W router Control signal
5		EPOS board	1.10.04.0000 086	BK3	Motion control signal transfer between DSP sever drivers
6		CCD module	1.10.03.0000 362	BK3	Combined with red-light and camera



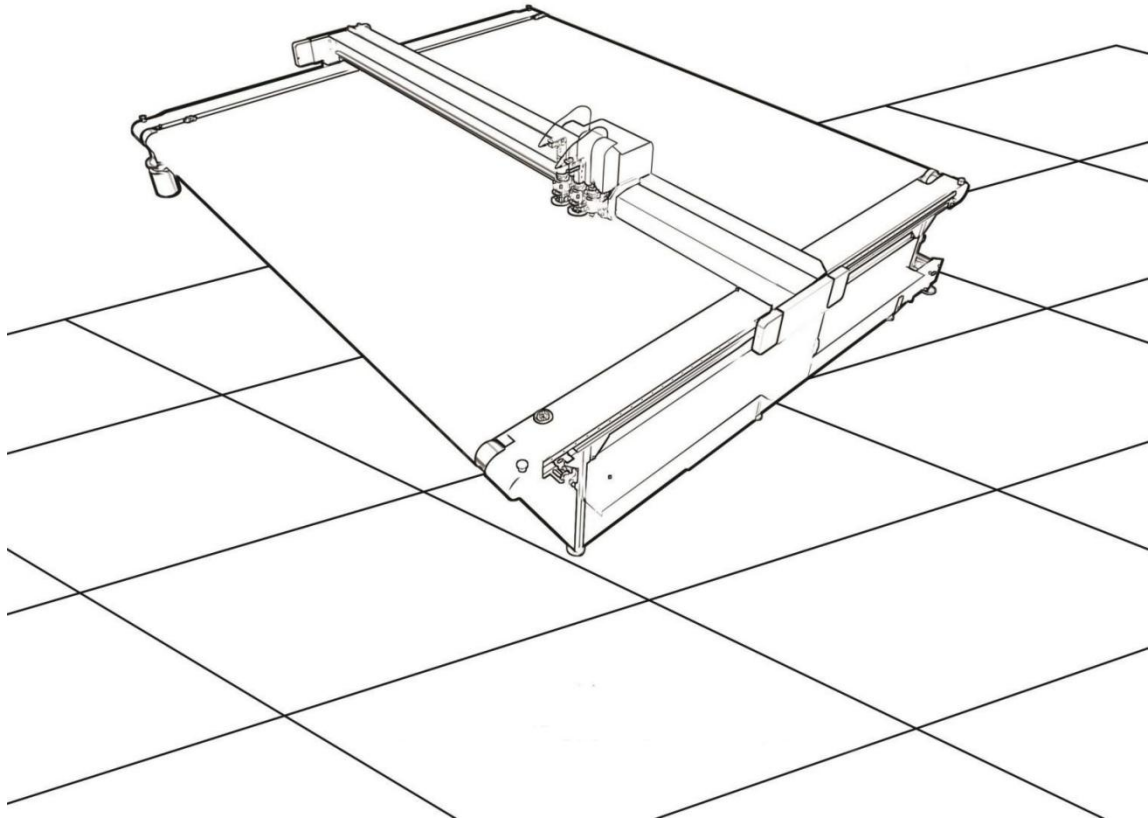

## TK3S Accessories and Consumables





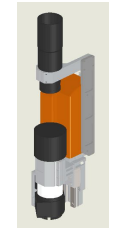

#### 4. TK3S - Series

Item	Designation
1	Combine the modules
2	Circuit boards and CCD module

#### Combine the modules

Item	Figure	Name	Article no.	Version	Description
1		Universal cutting head	1.10.03.000 0083	BK3.TK3S. TK4S	Can hold tools like EOT . POT . UCT . KCT . 350W router spindle etc .
2		Notch & Punch head	1.10.03.000 0528	BK3.TK3S. TK4S	Can make I . V . O shape mark on material
3		1KW	1.10.03.000 2097	BK3.TK3S. TK4S	1. Can cut acrylic, MDF, ABS, etc 2. Can be updated to bit auto changing function.
4		1.8KW	1.10.03.000 5025	BK3.TK3S. TK4S	1. Can cut acrylic, MDF, ABS, etc 2. Can be updated to bit auto changing function.
5		Labeling head	1.10.03.000 4349	BK3.TK3S. TK4S	Attaching label for pattern after printing

**Circuit boards and CCD module**

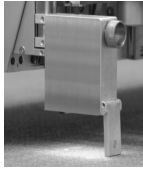
Item	Figure	Name	Article no.	Version	Description
1		Power& driver board	1.10.04.0000 097	TK3S.TK4S	DC power and signal relay board for DSP
2		B board	1.10.04.0000 099	TK3S.TK4S	Power and control signal for heads .camera ,red-light .
3		C board	1.10.04.0000 076	BK3.TK3S. TK4S	POT tool .350W router Control signal
5		EPOS board	1.10.04.0000 098	TK3S.TK4S	Motion control signal transfer between DSP sever drivers
6		CCD module	1.20.10.0000 254	TK3S.TK4S	Combined with red-light and camera

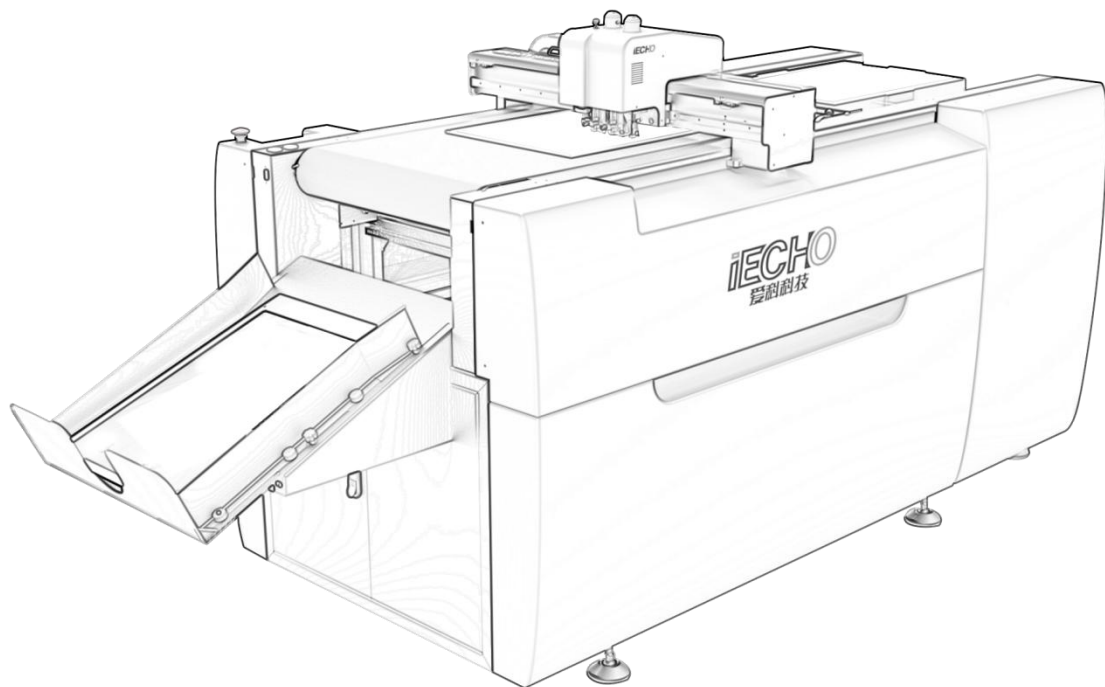

## PK Accessories and Consumables



## 5. PK - Series

Item	Designation
1	Combine the modules
2	PK spare parts list

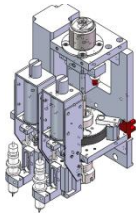
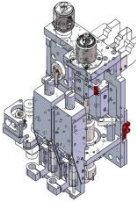

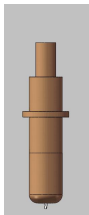

### 5.1 Combine the modules

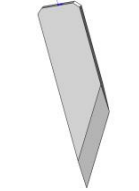
Item	Figure	Name	Article no.	Version	Description
1		Normal head module	1.10.03.0005 481	PK	The Module include 2 TW tools, creasing tool
2		Grand head module	1.10.03.0005 510	PK	The Module include EOT tool, 2 TW tools, creasing tool
3		TW tool	1.10.03.0005 525	PK	Can be applied with 1.5 drag knife and 1.5 U-clamp knife
4		Magnet	1.20.10.0000 559	PK	To provide the Up & Down power for TW tool
5		TW blade holder	1.10.01.0006 204	PK	1.5 drag knife and 1.5 U-clamp knife holder

## 5.2 PK spare parts list

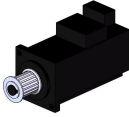
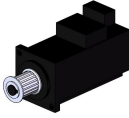

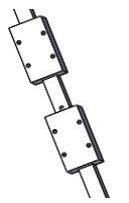



Item	Figure	Name	Article no.	Version	Description
1		1.5 Drag Knife	1.20.18.0000 245	PK	Knife for tungsten tool
2		1.5 U-Clamp Knife	1.20.18.0000 244	PK	Knife for tungsten tool
3		10° EOT Blade	1.20.18.0000 241	PK	Knife for EOT
4		30° EOT Blade	1.20.18.0000 242	PK	Knife for EOT
5		Conveyor Felt	1.20.17.0000 368	PK	Conveyor felt for PK0604
6		Conveyor Felt	1.20.17.0000 385	PK	Conveyor felt for PK0705
7		X - direction serve motor	1.10.03.0005 526	PK	Gantry motion in X direction power









Item	Figure	Name	Article no.	Version	Description
8		Y - direction serve motor	1.10.03.0005 527	PK	Module motion in Y- direction power
9		EOT tool rotation serve motor	1.10.03.0005 529	PK	EOT tool rotation motion power
10		Step Motor	1.10.03.0005 528	PK	Material platform Up& Down motion power
11		X-direction slider	1.20.14.0000 096	PK	
12		Y-direction rail and slider	1.20.14.0000 220	PK	
13		Camera		PK	Position mark capturing
14		EOT motor	1.20.07.0000 299	PK	Generate vibration motion of EOT

Item	Figure	Name	Article no.	Version	Description
14		EOT motor		PK	Generate vibration motion of EOT
15		Cylinder (Old)	1.20.04.0000 368	PK	Grabbing material from material platform
16		Cylinder (New)	1.20.04.0000 388	PK	Grabbing material from material platform
17		Material separator	1.20.02.0000 638	PK	Prevent the rest material going along with the top one
18		Sucking disc1	1.20.04.0000 369	PK	Suck material from platform
19		Sucking disc2	1.20.01.0001 146	PK	Suck material from platform
20		Tight nail	1.20.01.0001 156	PK	Fix the blade on EOT tool

## 6. Universal Parts List

Item	Figure	Name	Article no.	Version	Description
1		EOT	1.10.03.0000 307(1mm slot)	BK.BK2. BK3.TK3S. TK4S	EOT can cut medium density and thick(up to 20mm) material like foam board, com board, etc
2		POT	1.10.03.0001 297(1mm slot) 1.10.03.0001 054(1.5mm slot)	BK.BK2. BK3.TK3S. TK4S	POT can cut medium density and thick(up to 100mm) material like foam board, com board, etc
3		UCT	1.10.03.0000 335	BK.BK2. BK3.TK3S. TK4S	UCT can cut thin and medium density material like paper, card board, etc
4		DRT	1.10.03.0000 402	BK.BK2. BK3.TK3S. TK4S	DRT can cut fabric, textile, non-woven fabrics, etc
5		PRT	1.10.03.0000 403	BK.BK2. BK3.TK3S. TK4S	PRT can cut fabric, textile, non-woven fabrics,carpet,etc
6		Creasing tool	1.10.03.0000 335	BK.BK2. BK3.TK3S. TK4S	Creasing tool can make folding line on paper, card board, flute, etc
7		Kiss-cut	1.10.03.0000 295	BK.BK2. BK3.TK3S. TK4S	Kiss-cut can half cut sticker, vinyl, etc

Item	Figure	Name	Article no.	Version	Description
8		V-CUT	1.10.03.0000 313(E73)  1.10.03.0000 079(E74)	BK.BK2. BK3.TK3S. TK4S	V-CUT can make V-Shape groove on material
9		MILL 350W	1.10.03.0002 028	BK.BK2. BK3.TK3S. TK4S	Can cut acrylic, MDF, ABS, etc
10		DSP board	1.10.04.0000 010	BK.BK2. BK3.TK3S. TK4S.PK	Machine motion control, signal, control, etc.
11		GPRS&485 board	1.10.04.0000 095	BK.BK2. BK3.TK3S. TK4S.	Signal between machine and PC
12		QF Board	1.10.04.0000 089	BK3.TK3S.	Control Signal for valves of vacuum area
13		Video Card	1.20.10.0000 263	BK.BK2. BK3.TK3S. TK4S.	Video decode
14		Serial comm cable	1.20.15.0000 124	BK.BK2. BK3.TK3S. TK4S.	Receive and transmit signal between machine and PC



Item	Figure	Name	Article no.	Version	Description
15		Altitude Cruiser	1.10.03.0005 418	BK3.TK3S. TK4S.	Read the thickness difference on the felt surface, save the difference data to DSP.
16		Pneumatic Pen Module	1.10.03.0001 006	BK.BK2	Combined with red-light and pen
17		400W Delta Serve Driver	1.20.07.0000 016	BK.BK2. BK3.TK3S. TK4S.	Serve motor motion control
18		100W Delta Serve Driver	1.20.07.0000 017	BK.BK2. BK3.TK3S. TK4S.	Serve motor motion control
19		400W Delta Serve Motor	1.20.07.0000 031	BK.BK2. BK3.TK3S. TK4S.	Mechanical Motion Driving
20		100W Delta Serve Motor	1.20.07.0000 045	BK.BK2. BK3.TK3S. TK4S.	Mechanical Motion Driving
21		750W Yaskawa Serve Driver	1.20.07.0000 091	BK3	Serve motor motion control

Item	Figure	Name	Article no.	Version	Description
22		400W Yaskawa Serve Driver	1.20.07.0000 089	BK3	Serve motor motion control
23		750W Yaskawa Serve Motor	1.20.07.0000 090	BK3	Mechanical Motion Driving
24		400W Yaskawa Serve Motor	1.20.07.0000 088	BK3	Mechanical Motion Driving
25		Dongle key	1.20.10.0000 381	BK.BK2. BK3.TK3S. TK4S.PK	Software Key
26		Dongle key	1.20.10.0000 381	BK.BK2. BK3.TK3S. TK4S.PK	Software Key

## 7. Consumable Parts List

Item	Designation
1	Blades list
2	Milling Collects
3	Other accessories

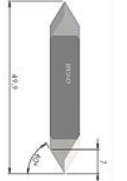
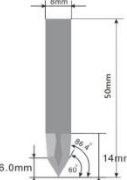
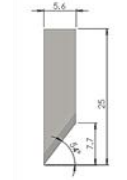
### 7.1 Blades list

Item	Figure	Name	Article no.	Version	Description
1		E13	1.20.18.0000 055	UCT	Tungsten steel Blade-1.5mm
2		E14	1.20.18.0000 083	UCT	Tungsten steel Blade-1.5mm
3		E16	1.20.18.0000 056	UCT.EOT	Tungsten steel Blade-0.63mm
4		E17	1.20.18.0000 057	UCT.EOT	Tungsten steel Blade-0.63mm
5		E17 Extended	1.20.18.0000 050	UCT.EOT	Tungsten steel Blade-0.63mm

Item	Figure	Name	Article no.	Version	Description
6		E18	1.20.18.0000 053	EOT.POT	Tungsten steel Blade-0.63mm
7		E18L	1.20.18.0000 049	EOT.POT	Tungsten steel Blade-1mm
8		E20	1.20.18.0000 067	EOT	Tungsten steel Blade
9		E21	1.20.18.0000 058	EOT	Tungsten steel Blade-0.63mm
10		E22	1.20.18.0000 059	EOT	Tungsten steel Blade-0.63mm
11		E25	1.20.18.0000 071	EOT	Tungsten steel Blade-1.0mm
12		E26	1.20.18.0000 061	EOT	Tungsten steel Blade-0.63mm







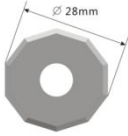
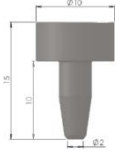
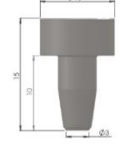







Item	Figure	Name	Article no.	Version	Description
13		E28	1.20.18.0000 062	EOT.POT	Tungsten steel Blade-0.63mm
14		E28-2	1.20.18.0000 047	EOT.POT	Tungsten steel Blade-1.0mm
15		E41	1.20.18.0000 063	EOT.POT	Tungsten steel Blade-0.63mm
16		E42	1.20.18.0000 064	EOT.POT	Tungsten steel Blade-0.63mm
17		E46	1.20.18.0000 122	UCT	Tungsten steel Blade-1.5mm
18		E61	1.20.18.0000 065	POT	Tungsten steel Blade-1mm
19		E62	1.20.18.0000 066	POT	Tungsten steel Blade-1mm



Item	Figure	Name	Article no.	Version	Description
20		E63	1.20.18.0000 169	POT	Tungsten steel Blade-1mm
21		E64	1.20.18.0000 069	POT	Tungsten steel Blade-1.5mm
22		E64-2	1.20.18.0000 073	POT	Tungsten steel Blade-1mm
23		E64-4	1.20.18.0000 081	POT	Tungsten steel Blade-1mm
24		E73	1.20.18.0000 099	V-CUT	V-CUT Blade
25		E74	1.20.18.0000 134	V-CUT	V-CUT Blade
26		E50	1.20.18.0000 130	DRT.PRT	Driven Rotary Blade

Item	Figure	Name	Article no.	Version	Description
27		E51	1.20.18.0000 103	DRT.PRT	Driven Rotary Blade
28		E52	1.20.18.0000 051	DRT.PRT	Driven Rotary Blade
29		E1	1.20.18.0000 025	Kiss-cut	Kiss - cut Blade
30		E2	1.20.18.0000 026	Kiss-cut	Kiss - cut Blade
31		E81	1.20.18.0000 139	Puching	Punch Blade
32		E82	1.20.18.0000 140	Punching	Punch Blade
33		E83	1.20.18.0000 141	Punching	Punch Blade

Item	Figure	Name	Article no.	Version	Description
34		E84	1.20.18.0000 142	Punching	Punch Blade
35		EPI	1.20.18.0000 030	Punching	I-Shape Notch
36		EP2	1.20.18.0000 144	Punching	I-Shape Notch
37		EPV	1.20.18.0000 135	Punching	V-Shape Notch
38		EPV2	1.20.18.0000 136	Punching	V-Shape Notch
39		EPV3	1.20.18.0000 137	Punching	V-Shape Notch

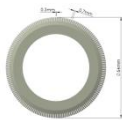
Item	Figure	Name	Article no.	Version	Description
41		ER1 3.175mm	1.20.18.000 0158		350W Milling Blade
42		ER2 4mm	1.20.18.000 0159		350W Milling Blade
43		ER62.1 6 2 6 60 1	1.20.18.000 0207		1KW/1.8KW Milling Blade
44		ER63.1 6 3 11 60 1	1.20.18.000 0201		1KW/1.8KW Milling Blade
45		ER64.1 6 4 22 60 1	1.20.18.000 0192		1KW/1.8KW Milling Blade
46		ER64.2 6 4 22 61 2	1.20.18.000 0202		1KW/1.8KW Milling Blade
47		ER64.3 6 4 14 60 1	1.20.18.000 0197		1KW/1.8KW Milling Blade

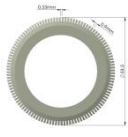
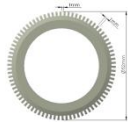
Item	Figure	Name	Article no.	Version	Description
48		ER65.1 6 5 22 61 1	1.20.18.000 0198		1KW/1.8KW Milling Blade
49		ER66.1 6 6 20 61 2	1.20.18.000 0199		1KW/1.8KW Milling Blade
50		ER66.2 6 6 22 61 2	1.20.18.000 0188		1KW/1.8KW Milling Blade
51		ER66.3 6 6 21.5 60 1	1.20.18.000 0208		1KW/1.8KW Milling Blade
52		ER6C4 6 10 C4 50 2	1.20.18.000 0193		1KW/1.8KW Milling Blade
53		ER6R4 6 10 R4 50 2	1.20.18.000 0194		1KW/1.8KW Milling Blade
54		PTK1 1.5mm Thick Cutting depth 1.1mm	1.20.18.000 0214		Performing Blade

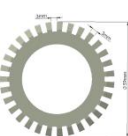
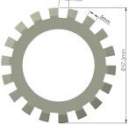
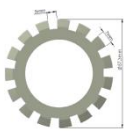
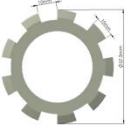
Item	Figure	Name	Article no.	Version	Description
55		PTK2 1.5mm Thick Cutting depth 1.1mm	1.20.18.000 0215		Performing Blade
56		PTK3 1.5mm Thick Cutting depth 1.1mm	1.20.18.000 0216		Performing Blade
57		PTK4 1.5mm Thick Cutting depth 1.1mm	1.20.18.000 0217		Performing Blade
58		PTK5 1.5mm Thick Cutting depth 4mm	1.20.18.000 0218		Performing Blade
59		PTK6 1.5mm Thick Cutting depth 4mm	1.20.18.000 0219		Performing Blade
60		PTK7 1.5mm Thick Cutting depth 4mm	1.20.18.000 02120		Performing Blade
61		PTK8 1.5mm Thick Cutting depth 4mm	1.20.18.000 0221		Performing Blade

**7.2 Milling Collects**

<b>Item</b>	<b>Figure</b>	<b>Name</b>	<b>Article no.</b>	<b>Version</b>	<b>Description</b>
1		3.175mm	1.10.01.0002 759		350W Milling Spindle
2		4.0mm	1.10.01.0002 273		350W Milling Spindle
3		6.0mm	1.10.01.0002 274		350W Milling Spindle
4		6.0mm	1.10.01.0005 274		1KW Milling Spindle



### 7.3 Other accessories

Item	Figure	Name	Article no.	Version	Description
1		Carbon Connector	1.10.01.0000 744		EOT Part
2		Felt No.1 (Thickness 2.8mm,made in Europe)	Part number varies from different machine size		For convey System / Spare felt for router
3		Felt No.2 (Thickness 4mm,Made in China)	Part number varies from different machine size		For convey System / Spare felt for router
4		Felt No.3 (Thickness 4mm,Made in China)	Part number varies from different machine size		Spare felt for router
5		Felt No.4 (Thickness 2mm,made in Europe)	Part number varies from different machine size		Exclusive felt for router
6		Felt No.5 (Thickness 3mm,Made in China)	Part number varies from different machine size		For convey System / Static Table